



PARK CITY SAILING ASSOCIATION

PO Box 981236, Park City, Utah 84098
www.SAILpc.org info@ParkCitySailing.org

SAILING INSTRUCTIONS 2015 Park City Sailing Association Fall Regatta September 19-20, 2015

1. **Organizing Authority:** these events are organized by the Park City Sailing Association.

2. **Events:**

- a. The NA Laser Class Association “No Coast Championships” – on Race Circle 1
- b. The PC Sailing Association Fall Regatta which will consist of 5 fleets:
 - i. Division I (Race Circle 1) Multi-hull (PHRF)
 - ii. Division II (Race Circle 1) Ultimate 20
 - iii. Division III (Race Circle 1) Elliott 6m
 - iv. Division IV (Race Circle 1) Lasers
 - v. Division V (Race Circle 2) Optimist and C 420

3. **Schedule:**

<i>Date</i>	<i>Time</i>	<i>Event</i>
<i>Saturday, September 19</i>	<i>8:30 –10:45 a.m.</i>	<i>Registration, Measurement</i>
<i>Saturday, September 19</i>	<i>11:00 a.m.</i>	<i>Competitor’s Meeting</i>
<i>Saturday, September 19</i>	<i>12:00 noon</i>	<i>First Warning for races</i>
<i>Saturday, September 19</i>	<i>6:30 p.m.</i>	<i>Commodore’s Ball</i>
<i>Sunday, September 20</i>	<i>11:00 a.m.</i>	<i>First Warning for races</i>
<i>Sunday, September 20</i>	<i>4:00 p.m. (approx.)</i>	<i>Trophy Presentation @Jordanelle</i>

- a. There shall be no make-up races due to cancellations.
- b. Subsequent races will be held as soon as possible after the end of the previous race.
- c. There will be no warning signal after 3:00pm on Sunday, September 20th

4. **Eligibility and Entry**

- a. Eligible crews may enter by completing registration and liability waivers with the organizing authority and paying the entry fee.
- b. Participants under the age of 18 shall submit a waiver of liability signed by a parent or legal guardian.
- c. This event is open to sailors of all classifications as described in the ISAF Regulation, ISAF Sailor 22 Classification Code. A start will be given for any class consisting of 3 or more boats.

5. **Rules:** the regatta will be governed by:

- a. The Racing Rules of Sailing 2013-2016 (RRS)
- b. The prescriptions of the United States Sailing Association (US Sailing)
- c. The rules of each individual class.
 - i. NOTE: Lasers must compete with class legal sails.



PARK CITY SAILING ASSOCIATION

PO Box 981236, Park City, Utah 84098
www.SAILpc.org info@ParkCitySailing.org

- d. These Sailing Instructions and any appendices thereto
- e. The rules of the Jordanelle State Park

6. Notices to Competitors:

- a. Notices to competitors will be posted on the official regatta notice board located near the launching ramp, by registration.

7. Changes in Sailing Instructions:

- a. These sailing instructions may be amended as necessary. Any change in the Sailing Instructions will be posted at least one (1) hour before the first warning signal on the day it will take effect, except that any changes to the schedule of races will be posted by 6:00pm the night before it will take effect.

8. Signals Made Ashore:

- a. Signals made ashore will be displayed from the Race Committee (RC) Signal Boat.
- b. When flag "AP" is displayed ashore, the warning signal for the next race will be made not less than 20 minutes after the AP is lowered.

9. Inspection and Measurement

- a. Class rules will apply for each class with the exception Lasers can use non class sails

10. Race Course – there will be two race circles:

- a. Circle 1 will be approximately $\frac{3}{4}$ of NM south east of the PWC ramp where racing will be conducted for **Divisions I-IV**.
- b. Circle 2 will be approximately 200-300 yards S of the PWC ramp for **Division V**.
- c. The diagrams attached as Appendix A show the courses for Circle 1.
- d. The diagrams attached as Appendix B show the courses for Circle 2.
- e. All course diagrams show the starting line, the marks, the direction marks are to be rounded, their order of rounding, and the finish line.
- f. The courses will be designated W (windward/leeward), and T (triangle).
- g. The course will be displayed for each race on a course board on the stern of the RC Signal Boat. The display will include the division number and the course designation.

11. Marks

- a. Marks of the course will be orange buoys.
- b. If the position of the next mark must be changed, RRS 33 will apply and the RC may use an inflatable yellow mark as the new mark.

12. Starts/Finish

- a. Races will be started using the Sound-Signal Starting System described in RRS Appendix S (3 min whistles).
- b. For Circle 1, the start line will be between an orange flag displayed on the RC Signal Boat and a white buoy. The finish line will be between an orange flag displayed on the RC Signal Boat and a white buoy on the opposite side of the RC Signal Boat from the start line (see Appendix A).
- c. For Circle 2, the start and finish lines will be between an orange flag displayed on the RC Signal Boat and a white buoy (see Appendix B).



PARK CITY SAILING ASSOCIATION

PO Box 981236, Park City, Utah 84098
www.SAILpc.org info@ParkCitySailing.org

- d. In the event of a Course shortened to the windward mark, the finish line will be between the windward mark and the RC Mark Boat.
- e. For Circle 1, in the event of a course shortened to the leeward mark, the finish line will be between the RC Signal Boat and the finish mark. This changes RRS 32.2.

13. Individual Recalls

- a. Individual recalls will be signaled in accordance with RRS rule 29.1.
- b. The RC Signal Boat and the RC Pin Boat will attempt to hail OCS boats. The failure of any boat to hear a hail, hear the hail of some but not all OCS boats, or RC failure to hail any or all OCS boats shall not be grounds for redress.

14. General Recalls

- a. In the event of a General Recall, RRS 30.1 will automatically be in effect, and the "I" flag will be displayed during the subsequent starting sequence. The "Z" or Black flag may be displayed instead of the "I" flag after any General Recall, and RRS 30.2 or RRS 30.3, respectively, will be in effect.

15. Time Limits

- a. The time limit for all races will be 60 minutes for the first boat to finish. Boats finishing more than twenty minutes after the first finishing boat shall be scored DNF. This changes RRS 35.

16. Penalties for Rule Infractions

- a. RRS 44 applies, no changes.

17. Protests and Requests for Redress

- a. A boat intending to protest an alleged rule infringement shall notify the Race Committee of her intention immediately after finishing. They shall attempt to provide the sail number of the boat(s) being protested. This changes RRS 61.1(a).
- b. Protests shall be written on forms available at the Notice Board or at the Race Office and delivered to the Race Desk within 45 minutes after the race committee boat docks.
- c. A list of protests along with the location and times of each protest hearing will be posted on the official notice board within 15 minutes of the end of protest time. This posting constitutes the notification required in RRS 61.1(b) and 63.2. It is the responsibility of each participant to check the posted schedule of protest hearings.
- d. Only the Race Committee, not a competitor, is permitted to protest a boat for breaking Sailing Instruction 19, 20, 21 and 23. This changes RRS 60.1(a).

18. Scoring

- a. The Low Point Scoring System, RRS Appendix A4, will be used except as modified below.
- b. Ten races are scheduled for the regatta.
- c. Completing a minimum of one race will constitute the regatta.
- d. If five races are completed, each boat's worst score will be excluded. If nine are completed, each boat's next worst score will also be excluded. This changes RRS Appendix A2.

19. Radio Communication

- a. A boat shall neither make radio transmissions while racing nor receive radio communications not available to all boats. This restriction also applies to mobile telephones.



PARK CITY SAILING ASSOCIATION

PO Box 981236, Park City, Utah 84098
www.SAILpc.org info@ParkCitySailing.org

20. Support Boats

- a. Team Leaders, coach boats, parents and other support personnel shall stay outside areas where boats are racing from the time of the preparatory signal until all boats have finished or the RC signals a postponement, general recall or abandonment.
- b. Private support boats may only use the main powerboat launching area on the north side of the peninsula.

21. Disposal of Trash

- a. Boats shall not discharge trash into the Jordanelle Reservoir. The penalty for breaking this rule will be at the discretion of the jury and may include adding points to a boat's score in the race or series, or disqualification from the series.

22. Safety Regulations

- a. Competitors may be subject to disqualification for interfering with commercial traffic. Boats violating USGC Inland Navigation Rules Part B, as stated in the Inland Navigation Rules Act of 1980 (Public Law 96-591, 94 Stat. 3415, 33 U.S.C. 2001-2038) or boats that are given a five blast warning of five short sounds will be subject to protest by the Race Committee.
- b. All competitors shall wear, while on the water, other than brief periods while adding or removing clothing, an approved PFD (US or Canadian Coast Guard).
- c. A boat retiring from a race shall make their best effort to notify a Race Committee vessel before leaving the course.
- d. When the RC displays code flag Y during the Division II start sequence, the Elliot 6M class will race with main and jib only (no spinnaker).

23. Prizes

- a. Prizes will be awarded based on number of competitors in each class.

24. Risk, Disclaimer of Liability and Personal Conduct

- a. Competitors participate in the regatta at their own risk. See Rule 4 (Decision to Race). The Organizing Authority will not accept any liability for material damage or personal injury or death sustained in conjunction to or prior to, during, or after the regatta.
- b. The competitor will accept full responsibility for his/her actions during any activity related to the event. This includes on-shore activities before, during, and after the regatta.
- c. Competitors are required to abide by the State Park Rules.
- d. Competitors using Park City Sailing Association owned Elliott 6M, Laser or Optimist Pram are required to avoid contact with any other vessel or stationary object at all times. Any damage to a Park City Sailing Association vessel is the responsibility of the individual competitor, and the competitor may be required to pay for damage repair. This includes damage to, but is not limited to, hull, hardware, sails, running and standing rigging, keel or centerboard, rudder.



PARK CITY SAILING ASSOCIATION

PO Box 981236, Park City, Utah 84098
www.SAILpc.org info@ParkCitySailing.org

Appendix A

Course W (Circle 1)

Start, 1p, 3p, 1p, Finish

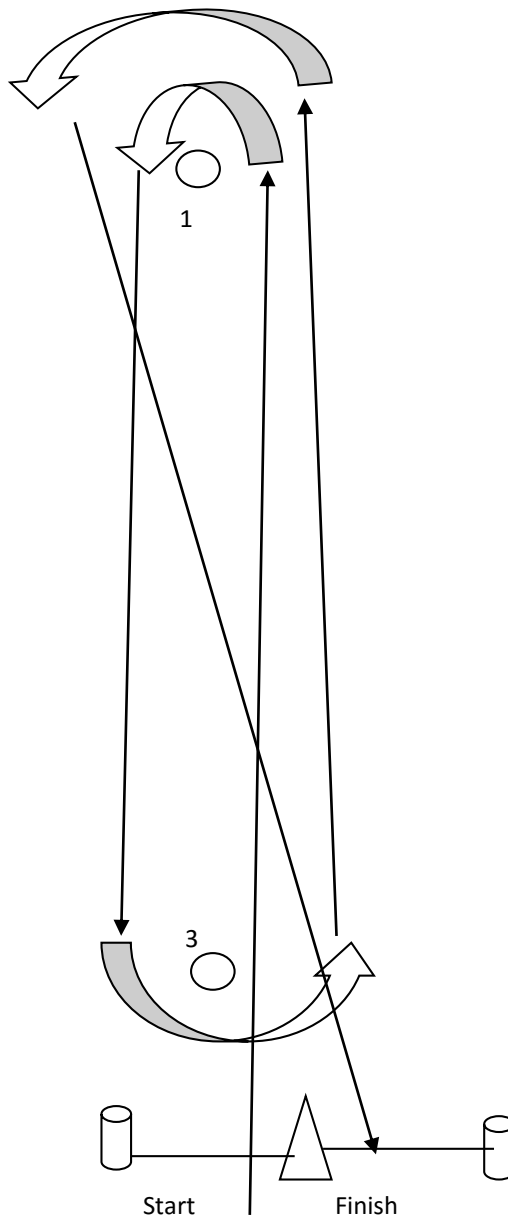



PARK CITY SAILING ASSOCIATION

PO Box 981236, Park City, Utah 84098
www.SAILpc.org info@ParkCitySailing.org

Course T (Circle 1)

Start, 1p, 2p, 3p, 1p, Finish

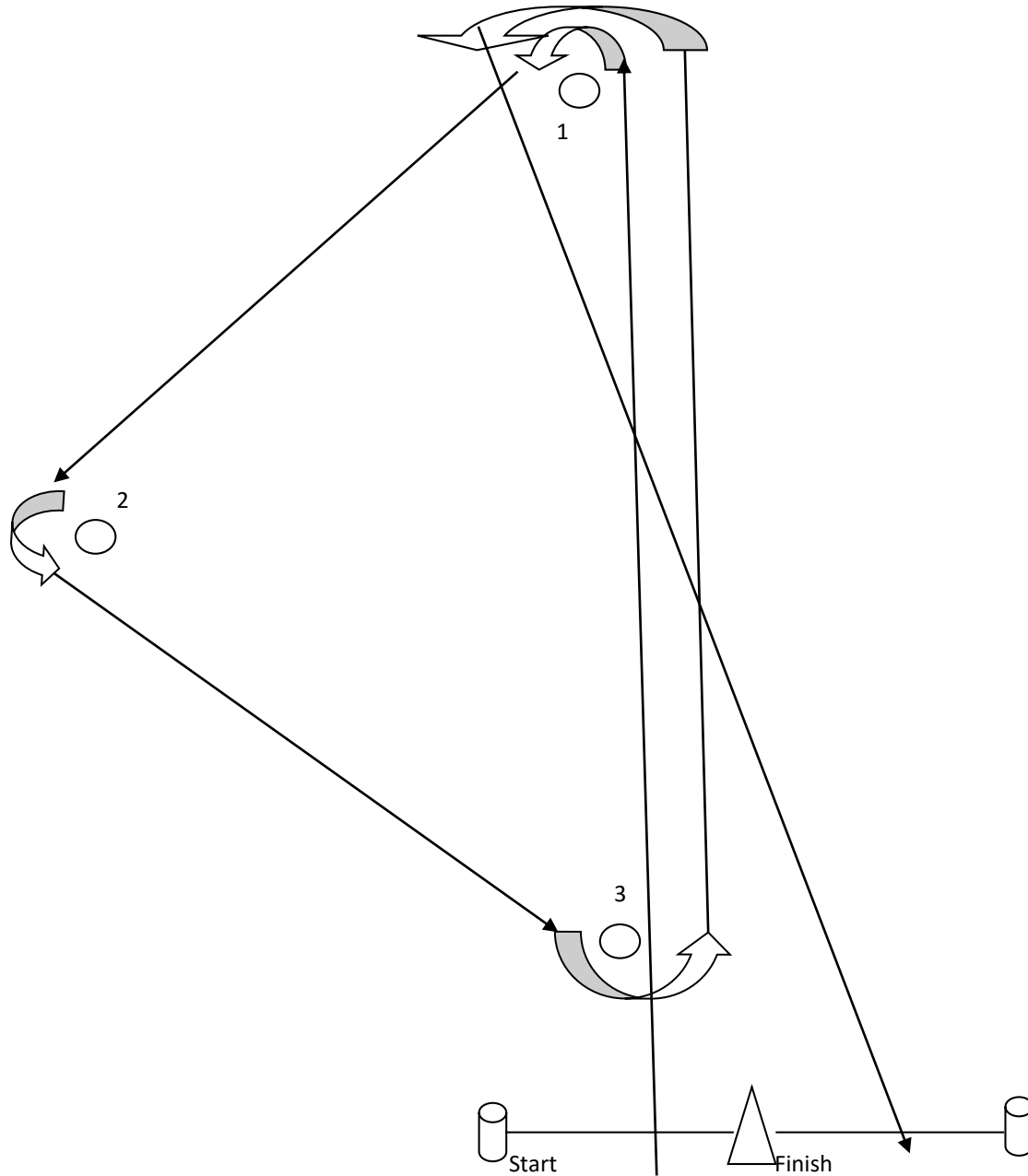



PARK CITY SAILING ASSOCIATION

PO Box 981236, Park City, Utah 84098
www.SAILpc.org info@ParkCitySailing.org

Appendix B Circle 2

Course W

Start (A-B), 1p, 2p, Finish (A-B)

